

Part number
CMI 03



Brief description:

bulkhead mounting housings with 2 levers, size "57.27" insulated 830V, insulated 830V version, IP66

Product description

Version	insulated 830V version
Series	Bulkhead mounting housings with 2 levers
Product type	with 2 levers
Family	830V enclosures for CME inserts
Size	size "57.27" insulated 830V

Technical data

Material	metal
IP degree of protection	IP66 (and IP69K DIN 40050 - 9)

Further technical details

Weight	156,00 g
---------------	----------

Approvals / Standards

Quality mark	 (type:4/4X/12),  , EAC
Conformity	CQC, CE

General ordering information

EAN13 code	8015747030526
Tariff number	85369095

Packaging Information

Packaging length	325,00 mm
Packaging height	180,00 mm
Packaging width	180,00 mm
Packaging weight	3,12 kg
Packaging volume	10,53 dm ³
Packaging description	Carton box
Packaging quantity	20 Pcs
Packaging EAN code	8015747234122
Sub-packaging weight	0,78 kg
Sub-packaging description	Plastic pakaging
Sub-packaging quantity	5 Pcs
Sub-packaging EAN barcode	8015747030533

Part number

CMI 03



Catalogue drawings

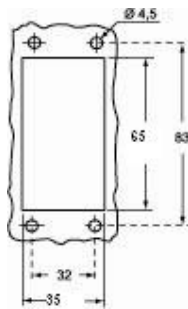

Catalogue drawings

CMI

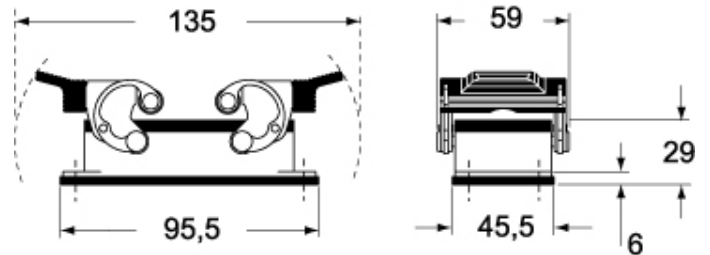

CMI CS/CP

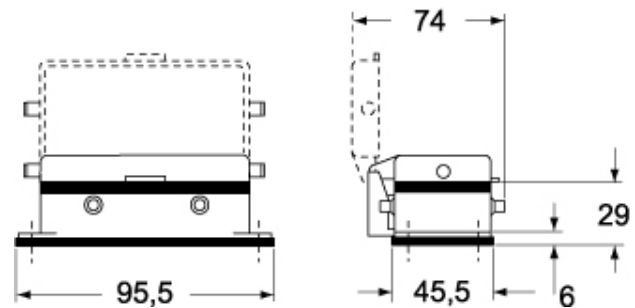

Notes

Inserts CX 02 4AF - CX 02 4AM:

- characteristics according to EN 61984:
(40A 1000V 8kV 3)
(40A 1600V 12kV 2)

- inserts for Ø 4mm cables, section: 2.5-8 mm² - AWG 14-8
- footprint 1 module

Inserts CX 02 4BF - CX 02 BM:

- characteristics according to EN 61984:
(40A 1000V 8kV 3)
(40A 1600V 12kV 2)

- inserts for Ø 4.8 mm cables, section: 6-10 mm² - AWG 10-8
- footprint 1 module
- use flexible cables with sections from 2.5 to 10 mm² or extra flexible cables with sections from 2.5 to 6 mm²

- do not twist the cables
- fully insert the braids in the rear section of the contact